

# DVD PLAYERS

## Elite DVD Players:

### Technological Highlights for 2005/2006

- **Advanced Digital Direct Pixel Drive™ with VQE9**
- "Two-Dimensional Resolution Expander": Pixel Conversion IC for HDMI
- **108MHz/14-bit Video D/A Converter**
- 2-3 Pull-down PureCinema Progressive Scan Technology
- Component Frame DNR (DVD/VCD) PRO
- Chroma Upsampling Error Reduction
- Super Fine Focus Digital Filter
- Viterbi Decoder
- Versatile Parameters for Video Control
- Solid Audio Circuit Block for Superior Sound
- Pure Audio On/Off
- Hi-Bit Legato Link Conversion PRO
- High-Bit Legato Link Conversion
- Jog/Joystick Remote Control
- On-screen GUI (Graphical User Interface)
- Condition Memory
- Continuous Play Memory
- Custom-File 300 DVD/CD Playback
- **HDMI 1.1 Interface**
- i.LINK (IEEE1394)
- Steel Stabilizing Plate
- **Newly-Designed Triple-Layered Chassis**
- **Power-Supply Transformer for the Audio**
- Z-Concept

## Pioneer Innovations for Stunning Picture Quality

### Advanced Digital Direct Pixel Drive™ with VQE9 — All-Digital 10-bit Signal Processing and Transmission with HDMI (DV-79AVi)

The DV-79AVi, the latest Elite DVD player, features an upgraded version of the Pioneer-trademark Digital Direct Pixel Drive™. If you connect the player with a compatible A/V receiver or plasma display panel via the HDMI terminal, the new technology allows all-digital signal processing and transmission — with high 10-bit precision thanks to the newly-developed "VQE9" video-encoding LSI. Because the signals remain digital, they are free from conversion loss, delivering pictures with less noise and finer details than those with analog conversion. The player also converts up pixels for HDMI output. (See the figure at the bottom of the next page.)

#### VQE9 Video-Encoding LSI

The Advanced Digital Direct Pixel Drive™ features newly-developed VQE9 video-encoding LSI. This state-of-the-art device allows expansion to 10 bits, and all the processes for improving picture quality are performed on a single chip, including:

- Effective noise reduction with Component Frame DNR Pro (see page 20 for details)
- Highly-precise motion detection for more natural textures and smoother edges of moving images from video sources
- A wide variety of picture adjustment options
- High-resolution progressive pictures (PureCinema Progressive Scan)



#### "Two-Dimensional Resolution Expander": Pixel Conversion IC for HDMI

The Advanced Digital Direct Pixel Drive™ also features the "Two-Dimensional Resolution Expander" pixel conversion IC, which up-converts traditional DVD video signals to high-definition resolution in the most appropriate way for the connected monitor or TV. When the Elite DVD player is connected to a DLP projector with 1,280 x 720 pixels, for example, the pixel conversion IC up-converts the progressive 720 x 480 signals to progressive 1,280 x 720 signals which exactly fit the pixel count of the projector. The signals generated by the MPEG decoder pass through the Two-Dimensional Resolution Expander, and then are output via HDMI to an HDMI-compatible monitor or TV.

#### 108MHz/14-bit Video D/A Converter (DV-79AVi)

When video signals are output to non-HDMI devices, the Elite DVD player uses the high-grade 108MHz/14-bit Video D/A Converter. Combining 8x oversampling with high 14-bit precision, this premium device ensures superior linearity by preventing phase fluctuations. The converter also controls overshoot and undershoot without affecting the original signals, even when the picture has high contrast.

#### 2-3 Pull-down PureCinema Progressive Scan Technology (DV-79AVi/DV-45A)

##### Interlaced vs. Progressive Scanning

###### • Interlaced scan system — NTSC TV Standard

When you look at your TV screen close up, you will notice an image is made up of many horizontal lines. These are called scan lines: an image is painted on the screen by the scan lines that sweep from left to right, and top to bottom, in sequence. One screenful of TV picture is equivalent to a frame; by current NTSC TV standards there are 480 scan lines in each frame (480i).

All 480 scan lines that form an image are not sent to your TV at the same time; every other line is transmitted alternately every 1/60 second. In other words, in the first 1/60 of a second, odd-numbered lines (1st, 3rd, 5th, and so on), which total 240 and collectively form an odd-numbered field, are sent. In the next 1/60 of a second, even-numbered lines (2nd, 4th, 6th, and so on), which collectively form an even-number field, are transmitted to fill in the remaining space. In this way, a complete image, that is, a frame, is formed.

Such is NTSC interlaced scanning. With this system, lines are scanned for odd- and even-numbered fields alternately every 1/60 second, to build one frame every 1/30 second.

###### • Progressive scanning for double resolution of interlaced scanning

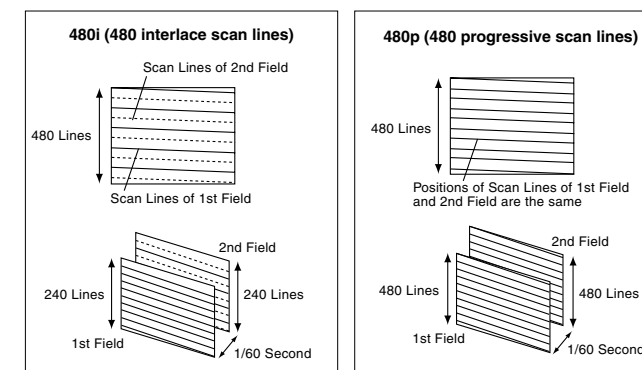

With interlaced scanning used by NTSC TV standards, the larger the display, the more noticeable the picture flicker. Progressive scanning was developed to solve this problem. With progressive scanning, all 480 lines are scanned from top to bottom in 1/60 of a second to build an entire frame (480p). With a progressive scan TV, the data for the odd- and even-numbered fields is stored in memory and undergoes field interpolation to convert from 30fps (frames-per-second) format to 60fps simulated format. Therefore, progressive scanning can provide double resolution of interlaced scanning, to present high-quality images with less flickering.

#### 2-3 Pull-down PureCinema Progressive Scan Technology

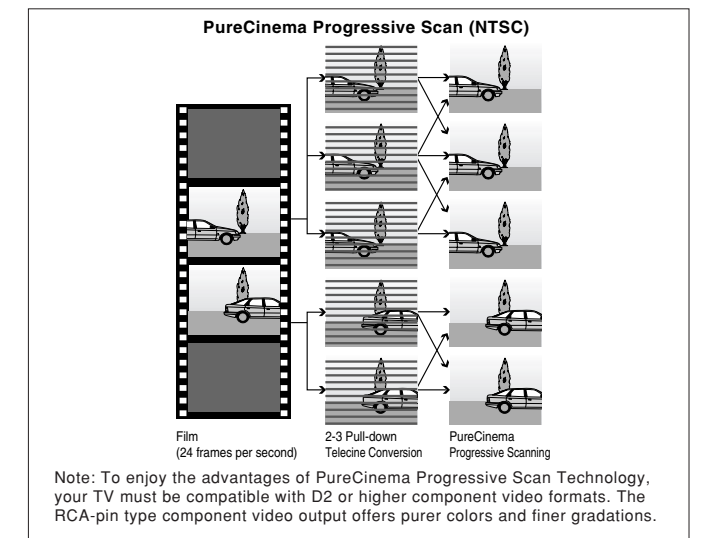

Normally there are 24 frames per second (24fps) on film. On DVD, movies are recorded in the same 24fps format, each frame containing the data for the entire 480 scanning lines (480p) for progressive scanning. Pioneer's 2-3 Pull-down PureCinema Progressive Scan Technology is exactly the technique to take advantage of delicately nuanced images recorded by progressive scanning. DVDs hold the data for inverse telecine conversion: When playing back film-originated sources, Pioneer's advanced scanning technology makes use of the data and inserts additional frames accurately. This allows the viewer to enjoy natural, film-like images. Pictures are smooth and sharp, with high resolution, free of bothersome artifacts like jagged edges on moving objects.

Note: With the DV-45A, PureCinema Progressive Scan directly turns 24fps progressive images from DVDs into 60fps progressive images. Because conventional progressive-interlace-progressive conversion is not used, this represents simpler, more efficient way of conversion.

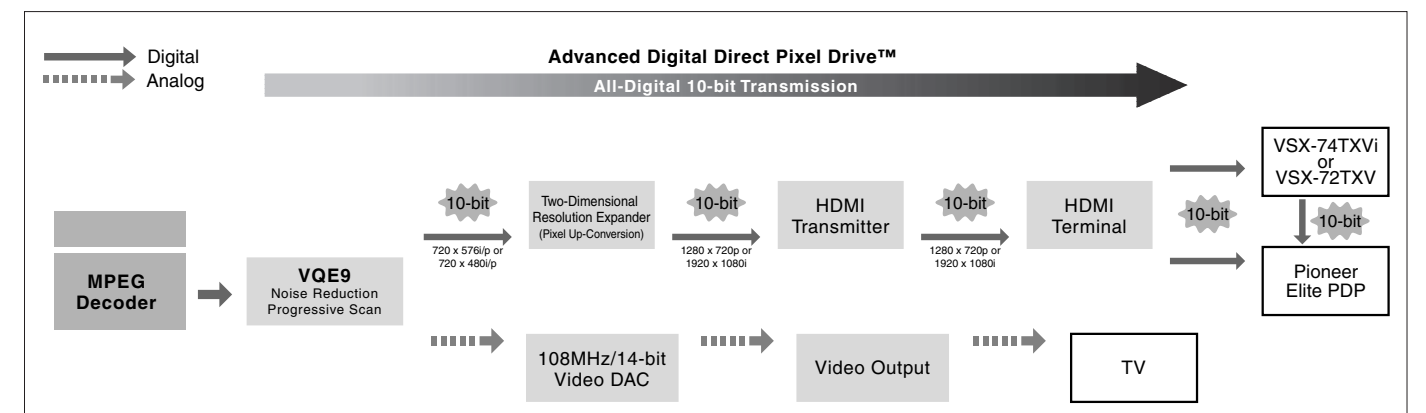

## Component Frame DNR (DVD/VCD) PRO (DV-79AVi)

DVD boasts a horizontal video resolution of more than 500 lines. Unfortunately, high resolution brings about a drawback of its own: minute noise is more visible. So Pioneer developed component frame cycling DNR (Digital Noise Reduction). It discriminates noise in each of the three components that comprise video signals — Y (luminance), P<sub>B</sub> and P<sub>R</sub>. Since it compares consecutive frames rather than consecutive fields, and processes individual components rather than composite signals, DNR provides superb noise reduction capability while retaining high resolution.

To further ensure higher video quality, Pioneer developed the advanced Component Frame DNR PRO. With the new version an optimum parameter is set for each of Y, P<sub>B</sub> and P<sub>R</sub> components to detect noise with higher precision. It's another reason the new Pioneer Elite DVD player delivers the quality that's much closer to the 35mm film than ever.

## Chroma Upsampling Error Reduction (DV-79AVi/DV-45A\*)

To record an entire movie or similar content on DVD, data must be compressed to fit the disc's 4.7GB capacity. This process reduces the color information (chroma signals) to half that of the original, causing Chroma Upsampling Errors — which translates into poor color resolution, or "color blur" of the reproduced pictures. With the Pioneer Elite DVD players, an MPEG decoder effectively reduces the Chroma Upsampling Errors\*\*, improving color fidelity and delivering much truer-to-original pictures than is possible with conventional DVD players.

\*Only with progressive scan output.

\*\*Reduction of Chroma Upsampling Errors is conducted only when the player determines that the loaded disc contains a movie source (24fps).

## Super Fine Focus Digital Filter (DV-79AVi/DV-45A\*)

The Super Fine Focus Digital Filter sharply attenuates unwanted high frequencies without removing necessary video frequencies. This dramatically cuts video noise and boosts the horizontal resolution to over 540 lines to provide detailed, sharp pictures.

\*DV-45A: Applies to interlace signals only.

## Viterbi Decoder (DVD)

Pioneer Elite DVD players feature two processors for accurate conversion. The DVD decoder functions to suppress errors using Viterbi Decoding: high-quality signals are sent from the disc to the AV-1 MPEG decoder with superb reliability.

### • Viterbi RF Decoding Process

The Viterbi Decoder boasts the ability to read data recorded on discs with exceptional precision. The Viterbi Decoder makes statistical calculations based on current, past and future data,



DVD Decoder Chip with Viterbi RF Decoding Processing

predicts probable transition points, and performs waveform reshaping. Data is reproduced with high stability and accuracy.

### • Accurate Digital Servo

This system detects the degree of disc warpage from the readout signal and automatically optimizes the focus and tracking servo gains, disc by disc, to reduce jitter and improve disc tracking ability.

## Technologies for Versatile Image Control

### Versatile Parameters for Video Control

Designed to deliver the best possible performance, the Video Adjust function features versatile image control for customized picture quality:

**Progressive Motion:** SLOW for static pictures, FAST for fast-moving pictures.

**NR:** Included are YNR and CNR, which reduce brightness and chroma noise, respectively. Frame DNR allows accurate noise reduction and elimination.

**Sharpness:** Allows well-focused, crisp images.

**Detail:** Sharpens the edges between high-contrast portions.

**Black/White level:** You can independently adjust the black level and white level for best contrast.

**Hue:** Adjusts the overall color of a picture.

**Chroma level:** Choose washed-out color or exaggerated, oversaturated color, or anything in between.

**Chroma delay:** Adjusts the timing between brightness and color to produce clarity of detail, removing blurriness and color smears. (DV-79AVi: Progressive sources only)

**Gamma correction:** Adjusts gradations by increasing or reducing the black level.

**Black setup:** Dark areas don't look muddy. You can see detail in dark scenes from progressive as well as interlace images.

**Fine Focus:** Sharpens or unsharpens the image.

**Contrast:** Sets the peak white level of the picture to stress or mute the difference between black level and white level.

**Brightness:** Adjusts the black level to provide an accurate image.

**HDMI Detail:** Adjusts the sharpness of edges in the HDMI video signal.

Moreover, you can adjust picture images to your liking — (TV (CRT), PDP and PROFESSIONAL with the DV-79AVi (analog video output) ; DIRECT, NATURAL and ENHANCED with the DV-79AVi (HDMI output); NORMAL, SPORTS and ART with the DV-F07) — and store three sets of combined parameters in memory.

	DV-79AVi	DV-45A	DV-F07**
Progressive Motion			
NR (Noise Reduction)			
Brightness NR (YNR) <sup>4)</sup>			
Chroma NR (CNR) <sup>4)</sup>			
Frame Digital NR (DNR)			3)
Sharpness	(High & Mid)	1)	3)
Detail			3)
Black/White Level			
Hue		1)	
Chroma Level		1)	
Chroma Delay	2)		3)
Gamma Correction			3)
Black Setup			
Fine Focus		3)	
Contrast		1)	
Brightness		2)	
HDMI Detail	4)		

\* Applies to interlace unless otherwise noted: 1) progressive/interlace, 2) progressive, 3) interlace, 4) with HDMI output only.

\*\* The DV-F07 does not feature progressive output.

## Technologies for Astounding Sound Realism

### Solid Audio Circuit Block for Superior Sound (DV-79AVi/DV-45A)

• All the decoding functions for DVD-Audio, DVD-Video and DTS are integrated in a single AV decoder chip. This allows simple and straightforward layout of signal paths.

• A DSP is used for configuring speaker systems, with Bass Management, gain control, and the distance in 0.5-foot increments adjusted accurately for DVD-Audio. All these parameters are available for SACD except for distance. It's also possible to choose "SMALL" for front speakers.

• Signals of 2-channel Linear PCM sources (CD, for instance) may be set to bypass the DSP by the CD DIRECT switch to ensure high-quality signal transfer.

• Each of the six channels features a 192kHz/24-bit D/A converter that accepts 192kHz PCM data and DSD (Direct Stream Digital) data directly. High-performance Super DAC (Burr-Brown PCM1738EG) is used for the front channels with DV-45A, and for all the six channels with the DV-79AVi. Moreover, the output from the DAC is a differential-current configuration to suppress common-mode noise.

• With the DV-79AVi, low-impedance capacitors are used in the power supply to reduce noise.

### Pure Audio On/Off (DV-79AVi)

Pure Audio provides the optimal conditions for reproducing analog audio. Turn the Pure Audio on, and the Elite DVD player automatically stops the signal transmission through Video output, HDMI, i.LINK, and Digital Audio outputs, and turns off the fluorescent display. This prevents the analog audio signals from being affected by interference from those circuits.

\*Pure Audio is activated when playback starts.

## Hi-Bit Legato Link Conversion (DV-F07) Hi-Bit Legato Link Conversion PRO (DV-79AVi)

In the process of recording and mastering a CD, low-level signals — signals lower than LSB (Least Significant Bit) of a CD's 16-bit system — are removed. But the absence of low-level signals causes quantization noise, resulting in a stepped waveform of converted analog signals — proof that reproduced sound is quite unlike the original. Hi-Bit Legato Link Conversion combines Pioneer-developed bit expansion technology with Legato Link for still better musical reproduction. This conversion process results in a waveform which is both smoother and closer to the original than conventional technology allows. The DV-79AVi comes with Hi-Bit Legato Link Conversion PRO that upsamples the audio signals of CDs and DVDs to 176.4kHz (from 44.1kHz) and 192kHz (from 48kHz or 96kHz), respectively. This processing extends the frequency response and improves transient response for wide-range sound.

## Easy Operation

### Jog/Joystick Remote Control (DV-79AVi/DV-45A/DV-F07)

The remote control for Elite DVD players features a jog dial and a joystick — the first for scan and other versatile playback, the second for navigating GUI on-screen menus.



DV-F07 Remote Control

### On-screen GUI (Graphical User Interface)

The on-screen display helps you set up the environment properly. Interacting with and assisted by the on-screen display on your TV, you can choose the GUI language, screen aspect ratio, DVD camera angle, parental lock level, and many other functions. Easy-to-follow GUI menus are logically layered to promote ease of use. With the DV-F07, you can control up to 300 discs through GUI. The DV-79AVi, and DV-45A come with advanced on-screen GUI that further simplifies the complicated DVD settings.

# Versatile Playback Functions

## Condition Memory (DVD) (DV-F07)

Load a disc, and the player automatically recalls the set of playback parameters you've selected for it — aspect ratio, soundtrack, subtitle, and OSD position. Once you've memorized the conditions for a disc, the Elite DVD player will identify the disc each time you play it and start playback in the conditions selected. Conditions for up to 100 discs can be memorized. Setup is as simple as pressing the "CONDITION" button when you're through viewing a disc. Memory is managed on the LRU (Least Recently Used) basis: the data (condition) for the disc that is not recalled longest is automatically erased to make room to store the data (condition) of a new disc.

## Continue Play Memory (DVD/VCD) (DV-F07)

When you interrupt play of a disc, Continue Play Memory (Last Memory) lets you store in memory the last settings for it — aspect ratio, soundtrack, subtitle, and other parameters — as well as the location where you left off. So, the next time you play the disc, you can resume play from the same point, using the same settings. For additional convenience, the settings in memory are not disturbed even if you have played other DVDs and adjusted settings in the interim; they are kept for instant recall. You can store the last settings for up to five DVDs and one VCD.

\* Continue Play Memory will be cleared once a loaded VCD is removed.

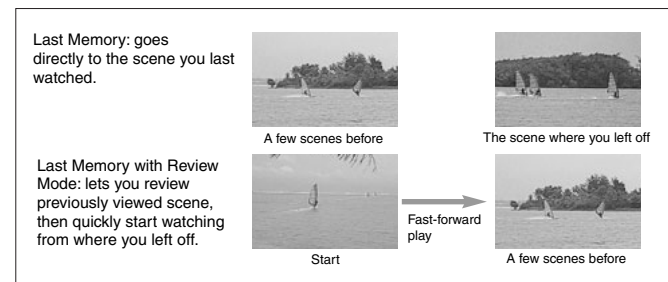

## Custom-File 300-DVD/CD Playback (DV-F07)

The DV-F07 is the world's first 300+1 DVD/CD changer. Couple two of them, and you can even control an incredible 601 discs — DVDs, CDs and combinations. In addition, it can play back CD-R and CD-RW discs you make on your own. Ease of use is enhanced with GUI (Graphical User Interface) allowing access and control of up to 300 discs.

### • Auto Update

At the touch of a button, all loaded discs are automatically given unique identities (addresses) by type (DVD or CD) and contents (TOC and CD Text). It makes possible a number of conveniences.

### • Disc Identification

Each disc — that is, its disc title and the artist's name — is identified not by a slot number in the rack but its contents stored in memory. So even when you move a disc from one slot to another, its title and artist name remain identified.

### • Title Input by Mouse or PC Keyboard

You can conveniently and efficiently enter disc titles, artist names, and custom file names for "data retrieval" using a PC keyboard or computer mouse\*.

\*Neither a PC keyboard nor a mouse is included in the package.

### • On-Screen Disc Management System

You can display lists of identified discs and artist names on-screen and select the desired disc using a PC mouse or a joystick. You can sort discs by title or artist name for easy search of a wanted disc.

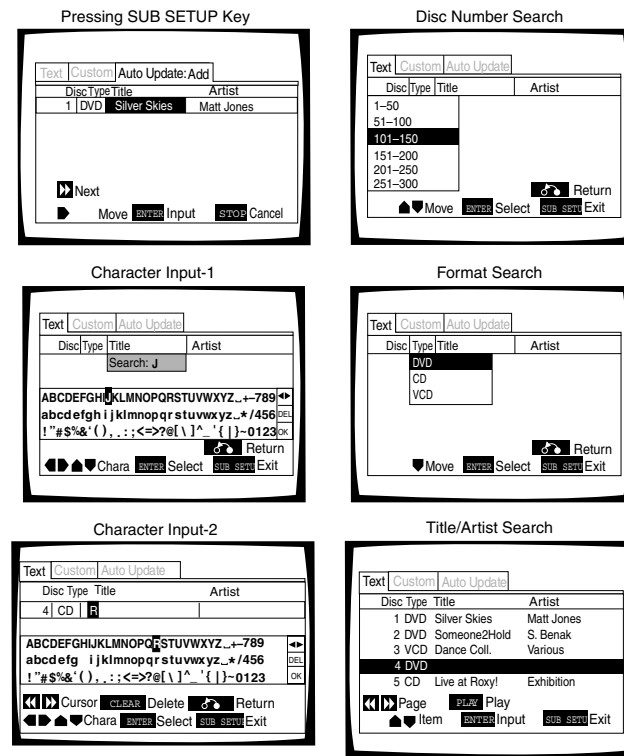

### • Custom Filing

The custom filing gives organization to your DVD/CD library. Refer to page 44 for details. With the DV-F07, you can divide 300 loaded discs into twenty groups or custom files (ten for audio, ten for video), each holding up to 300 discs. You can give a name of up to 12 letters to each of the twenty files for display on the screen and selection from the menu.

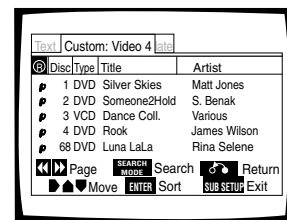

### • Menu Selection and Track Programming by Mouse

You can control the player using a computer mouse. At a click, a menu with a list of icons for play appears on the screen. Using the setup menu, you can adjust various parameters of the player. Moreover, you can program tracks from DVDs and CDs using the mouse and on-screen menus.

### • Control via Keyboard

Using F1-F5 keys and the numeric keypad on a PC keyboard, you can choose modes and efficiently enter text for disc titles and artist names from a keyboard.

### • Combining Audio with Video

When you combine two of the DV-F07, you can set one to output an audio signal and the other to output a video signal. This lets you enjoy video against the music or sound effect of your choice, or listen to music against the image of your choice.

### • Playback Control from External RS-232C Commander

The built-in RS-232C communications port allows external control of setup and playback functions using RS-232C commands.

# Inputs and Outputs

## HDMI™ 1.1 Interface (DV-79AVi\*)

The DV-79AVi features HDMI™ (High Definition Multimedia Interface), an uncompressed, all-digital audio/video interface, which is the first industry-supported unit of its kind. Its benefits over conventional terminals include:



- A high bit rate, up to 2.2Gbps for HDTV, for processing large amounts of uncompressed, high-quality data for both video and audio signals.
- Ensured lossless transmission for high picture and sound quality, as signals remain in a pure digital state, without D/A or A/D conversion.
- Transmission of both video and audio signals through a single cable, and with much smaller plugs than DVI, which handles video signals only.

HDMI is compatible with the pixel counts of all the current ATSC digital television formats, and supports up to eight channels of audio\*\*. In addition, the upgraded Version 1.1 supports DVD Audio, for high-spec sound. Pioneer's Elite Plasma Display Panels and new Elite A/V receivers — VSX-74TXVi and VSX-72TXV — also come with HDMI interfaces.

\*This unit has been designed to be compliant with HDMI (High Definition Multimedia Interface) Version 1.1. Depending on the component you have connected, using a DVI connection may result in unreliable signal transfer.

\*\*The DV-79AVi allows output of Linear PCM (2-channel and 5.1-channel) and compressed audio (Dolby Digital, DTS, and MPEG).

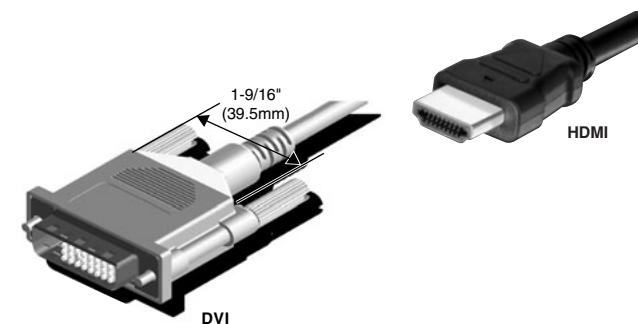

## i.LINK (IEEE1394) (DV-79AVi)

Today's sophisticated multi-channel audio recordings deliver a new level of sound quality unlike anything that came before. In order to deliver these digital signals, new methods of transmission were developed. i.LINK connectivity allows you to simplify your system and expand its performance at the same time. It's an advanced digital interface that provides an avenue for the transmission of DVD-Audio and SACD (Super Audio CD) music. In addition, i.LINK streamlines connection between the source player and the receiver. What used to take up to six different connections to achieve, i.LINK handles with one simple digital connection. i.LINK and  are the trademarks of Sony Corporation.

### Advantages

- **Easy operation**
  - A single i.LINK cable can deliver multichannel digital audio, as well as control and other types of data.
  - Transmission of DVD-Video, SACD, CD, VCD, DVD-RW, and MP3 data is supported.
  - Automatic output selection, auto play and input selection in conjunction with the VSX-59TXi or VSX-74TXVi Pioneer Elite A/V Receiver.
- **High-quality transmission**
  - PQLS (Precision Quartz Lock System) enables jitter-free transmission.
- **Network compatibility**
  - Supports S400 (400MB/sec.) transmission speed.
  - Two 4-pin connectors.
  - Connection with A&M Protocol (Audio & Music Data Transmission Protocol) equipment to enable the transmission of audio data and MIDI data on an IEEE1394 bus.
  - DTCP (Digital Transmission Content Protection) encryption to provide for digital connections between components.

## Audio/Video Connections

	DV-79AVi	DV-45A	DV-F07
HDMI Output	1		
Component Video Output	1*	1*	1*
6-Channel Audio Output	Yes*	Yes*	
Coaxial Digital Output	1*	1*	1*
Optical Digital Output	1	1	1
S-Video Output	2*	1*	1*
Composite Video Output	2*	1*	1*
Audio Output	1*	1*	1*
Coaxial Digital Input			1*
S-Video Input			1*
Video Input*			1*
Audio Input			1*
i.LINK (IEEE 1394)	2		

\* Gold Plated

On its rear panel, each Pioneer Elite DVD player is provided with an array of inputs and outputs for digital and analog sources. This means there are many ways to improve, upgrade and expand your home theater system.

Dolby Digital/Linear PCM digital outputs (optical and coaxial) can be connected to the matching inputs on a DTS-

